

TO-220F-2L PACKAGE OUTLINE

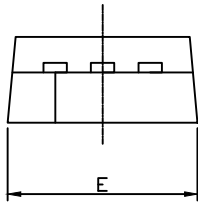

RECOMMENDED LAND PATTERN

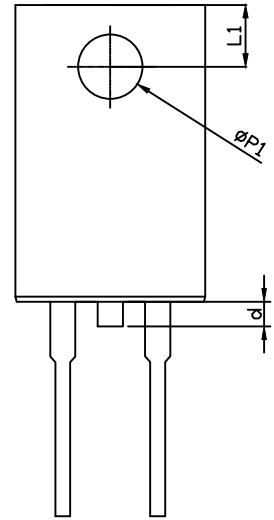
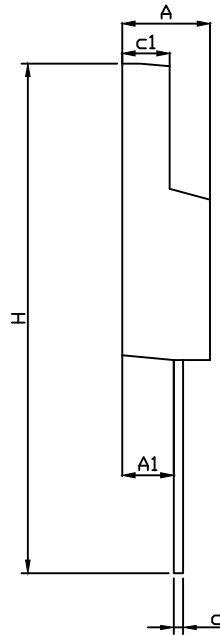
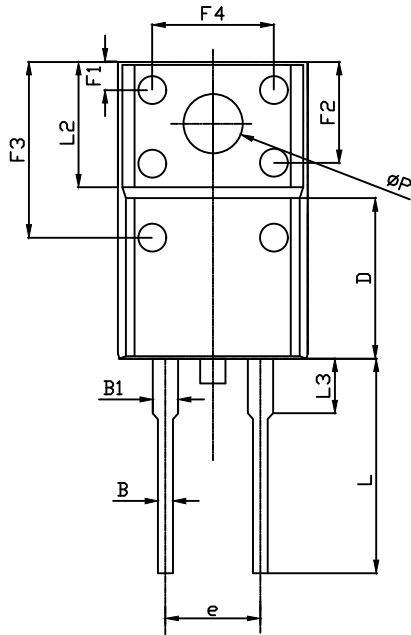
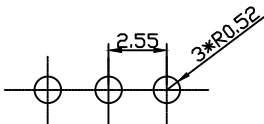

UNIT: mm

| | MIN | NOM | MAX |
|-----------|-------|---------|-------|
| A | 4.40 | 4.60 | 4.80 |
| A1 | 2.63 | 2.76 | 2.89 |
| B | 0.75 | 0.80 | 0.90 |
| B1 | 1.12 | 1.27 | 1.42 |
| c | 0.40 | 0.50 | 0.60 |
| c1 | 2.60 | 2.70 | 2.80 |
| D | 7.50 | 7.80 | 8.10 |
| d | - | - | 0.80 |
| e | - | 5.1REF | - |
| E | 9.86 | 10.00 | 10.10 |
| F1 | 1.90 | 2.12 | 2.40 |
| F2 | 5.00 | 5.30 | 5.65 |
| F3 | 8.70 | 9.00 | 9.30 |
| F4 | 6.20 | 6.50 | 6.80 |
| H | 27.80 | 28.30 | 28.80 |
| L | 13.10 | 13.30 | 13.50 |
| L1 | 2.85 | 3.00 | 3.15 |
| L2 | - | 6.70REF | - |
| L3 | 3.10 | 3.60 | 4.10 |
| ΦP | 3.00 | 3.30 | 3.60 |
| ΦP1 | 2.80 | 3.10 | 3.40 |