

# TO-220MF-3L PACKAGE OUTLINE

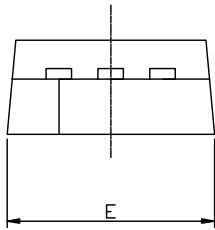

RECOMMENDED LAND PATTERN

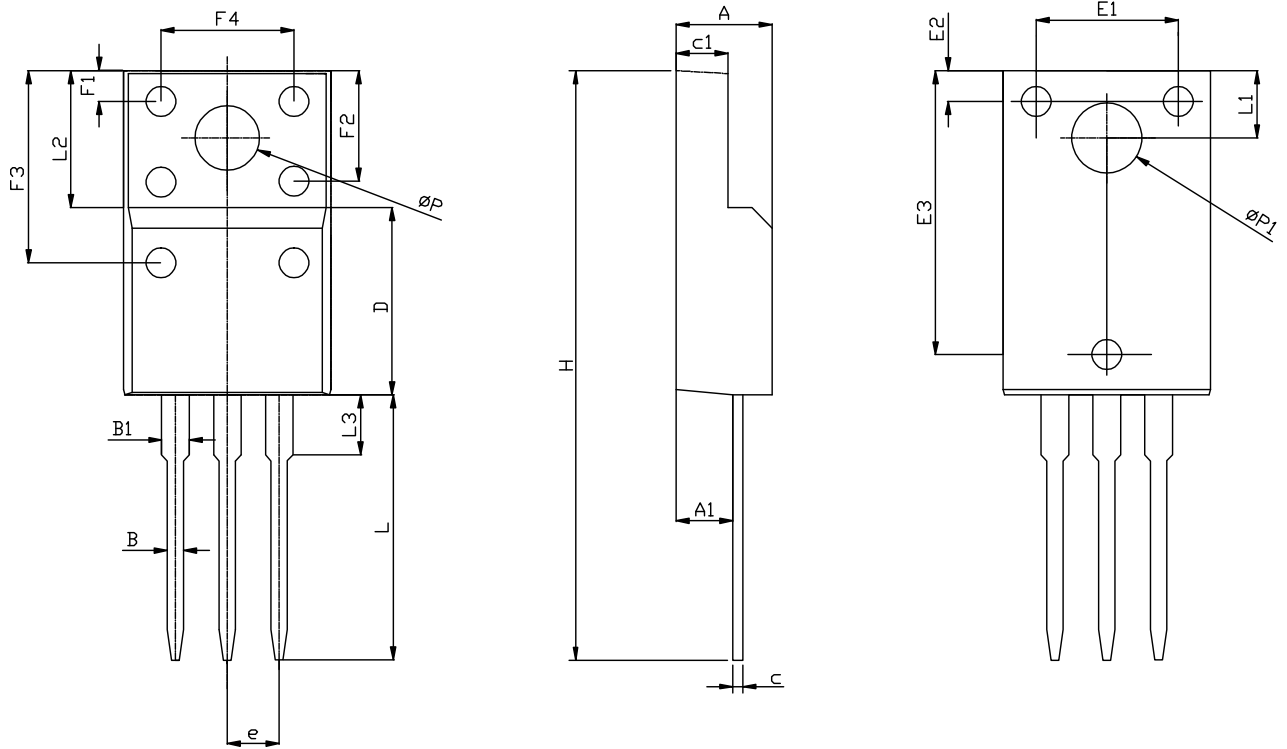
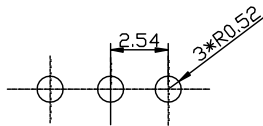

UNIT: mm

|     | MIN   | NOM     | MAX   |
|-----|-------|---------|-------|
| A   | 4.50  | 4.70    | 4.90  |
| A1  | 2.63  | 2.76    | 2.89  |
| B   | 0.75  | 0.80    | 0.90  |
| B1  | 1.15  | 1.35    | 1.55  |
| c   | 0.40  | 0.50    | 0.60  |
| c1  | 2.34  | 2.54    | 2.74  |
| D   | 8.87  | 9.17    | 9.47  |
| e   | -     | 2.54REF | -     |
| E   | 9.86  | 10.16   | 10.46 |
| E1  | 6.86  | 6.96    | 7.06  |
| E2  | 1.40  | 1.50    | 1.60  |
| E3  | 13.80 | 13.90   | 14.00 |
| F1  | 1.40  | 1.50    | 1.60  |
| F2  | 5.15  | 5.40    | 5.65  |
| F3  | 9.10  | 9.40    | 9.70  |
| F4  | 6.70  | 7.00    | 7.30  |
| H   | 28.50 | 29.00   | 29.50 |
| L   | 12.58 | 12.98   | 13.38 |
| L1  | 3.15  | 3.30    | 3.45  |
| L2  | -     | 6.70REF | -     |
| L3  | 2.63  | 2.93    | 3.23  |
| ΦP  | 2.90  | 3.18    | 3.48  |
| ΦP1 | 3.15  | 3.45    | 3.75  |